

HIGH PERFORMANCE BUTTERFLY VALVE HP 114



Lug type butterfly valve in double-eccentric construction. Reliable sealing even with extreme temperature and pressure conditions.

TECHNICAL DATA

Nominal diameter:	DN 50 - DN 1200 Metal seated up to DN 800 max. PN 16
Face-to-face:	EN 558 Series 20, optional Series 25 ISO 5752 Series 20 API 609 Table 1
Flange accommodation:	EN 1092 PN 10/16/25/40 (to DN 150) EN 1092 PN 10/16/25 (DN 200-DN 1200) ASME Class 150 AS 4087 PN16/21
Flange Surface Design:	EN 1092, Form A/B, ASME RF,FF
Top flange:	EN ISO 5211
Marking:	EN 19
Tightness check	Independent of flow-direction
- for R-PTFE seat:	EN 12266 (Leakage rate A)
- for Inconel seat:	EN 12266 (Leakage rate B) ISO 5208, Category 3
Temperature range:	-60°C to +600°C
Differential pressure:	≤ DN150 max. 40 bar > DN150 max. 25 bar
Vacuum:	up to 1mbar absolute

FEATURES

- Shut-off and control of gaseous and liquid media
- Disc has double-eccentric bearing
- Two seat ring systems available: R-PTFE and Inconel
- Seat variants:
 - soft seating (R-PTFE) max. 230°C
 - metallic seating (Inconel) max. 600°C
 - fire safe (PTFE/Inconel) max. 200°C
- Maintenance-free
- Long service life, even at high switching frequencies
- Firesafe API Standard 607 - 7th edition, ISO 10497-5: 2010

GENERAL APPLICATIONS

- Chemical and petrochemical industries
- Hot water and steam systems
- District heat supply
- Vacuum systems
- Shipbuilding
- Gas process technology
- Food industry
- Heavy duty services

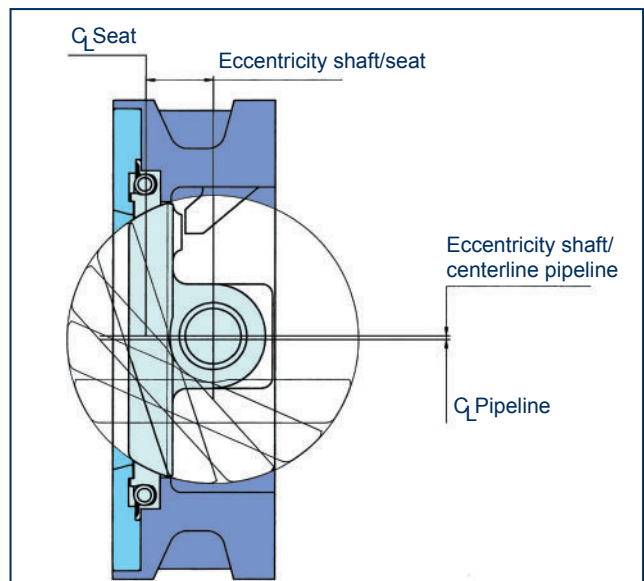

HIGH PERFORMANCE BUTTERFLY VALVE HP 114

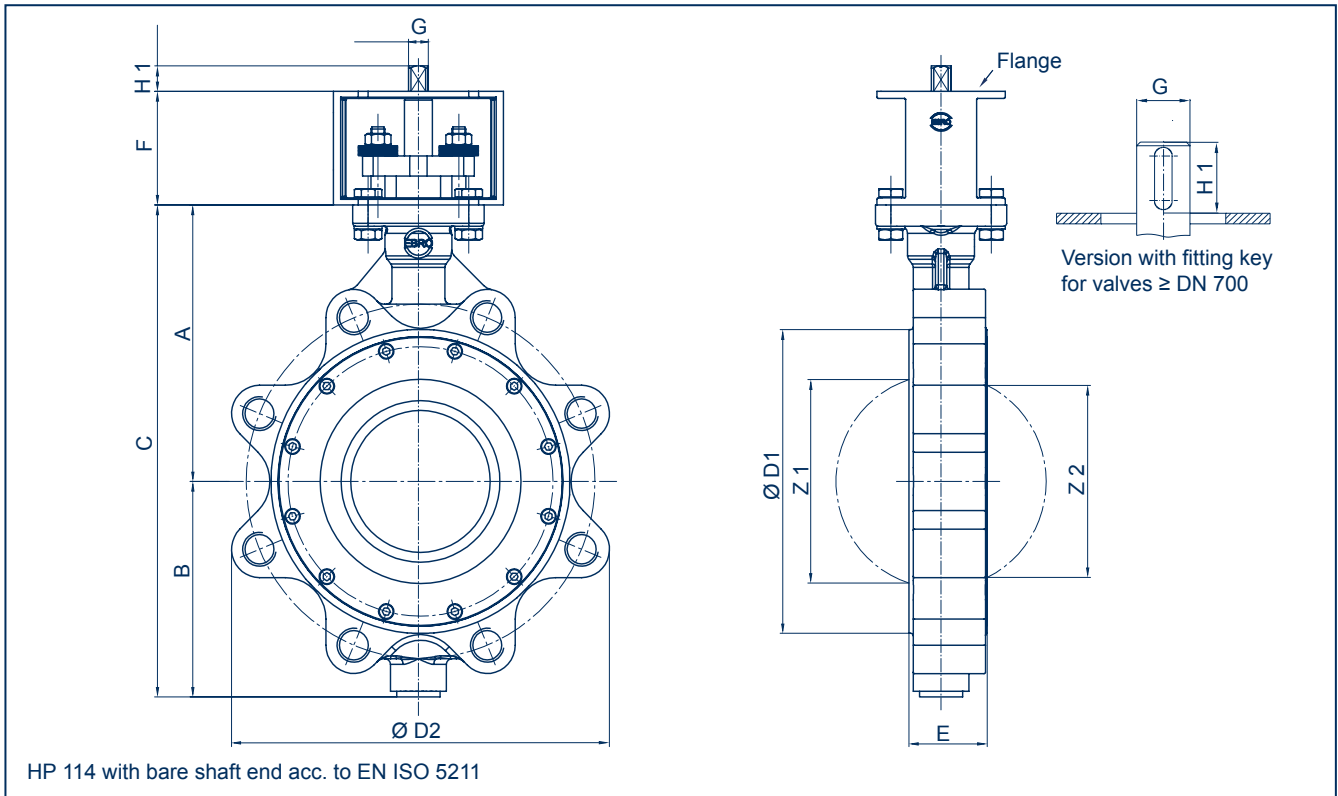

DN [mm]	Size [in]	Dimensions [mm]											Weight [kg]	
		A	B	C	D1	D2	E	F	Flange	G	H1	Z1		Z2
50-65	2-2½	133	99	232	112	180	43	80	F05/F07	12	15	41	-	6
80	3	142	113	255	138	200	46	80	F05/F07	12	15	71	54	9
100	4	158	124	282	160	235	52	80	F05/F07	12	15	94	82	12
125	5	181	140	321	192	260	56	80	F07/F10	14	18	115	105	16
150	6	195	154	349	216	295	56	80	F07/F10	14	18	144	135	19
200	8	225	191	416	270	356	60	80	F10/F12	17	18	187	181	30
250	10	268	222	490	326	425	68	80	F10/F12	22	23	235	229	44
300	12	300	255	555	378	480	78	90	F12	27	28	281	276	65
350	14	345	304	649	438	542	92	100	F14	27	28	323	316	104
400	16	375	339	714	488	606	102	100	F16	36	36	372	364	135
450	18	412	340	752	530	656	114	120	F16	36	36	427	427	174
500	20	425	399	824	593	716	127	120	F16	46	46	469	466	240
550	22	456	405	861	635	749	154	200	F25	46	46	526	526	268
600	24	490	468	958	692	834	154	200	F25	55	55	544	542	390
700	28	554	522	1076	820	916	165	200	F25	80	130	673	659	535
750 cl. 150-A	30	569	535	1104	857	965	165	200	F30	80	130	711	-	510
750 cl. 150-B	30	569	485	1054	812	878	165	200	F30	80	130	711	-	420
800	32	605	566	1171	902	1061	190	200	F30	90	130	748	736	570
900	36	660	637	1297	1006	1153	204	200	F30	100	145	847	833	800
1000	40	715	687	1402	1112	1298	216	200	F30	100	145	944	935	880
1200	48	815	789	1604	1328	1458	254	200	F35	110	185	1148	1175	1480

DN 50 - DN 150 = PN 40
 DN 200 - DN 1000 = PN 25
 DN 1200 = PN10/16

Subject to change without notice

HIGH PERFORMANCE BUTTERFLY VALVE HP 114

MATERIAL SPECIFICATION AND PARTS LIST

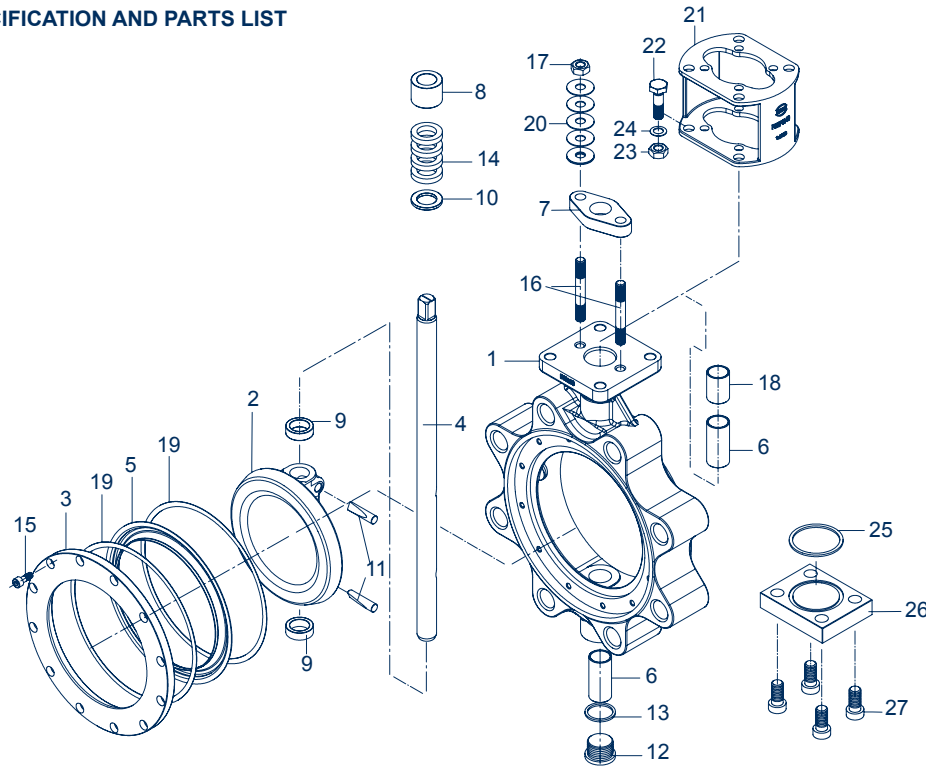

Pts. 25-27:
Cover plate for
valve ≥ DN 350

Pt.	Description	Material	Material No.	ASTM	Pt.c	Description	Material	Material No.	ASTM	
1	Body	Carbon Steel	GS-C25N	1.0619	WCB	15	Hex.-socket screw	Stainless Steel	A4-70	1.4401 B8M
		Stainless Steel	G-X5CrNiMo19-11-2	1.4408	CF8M	16	Threaded pin	Stainless Steel	A2-70	1.4301 B 8
2	Disc	Stainless Steel	G-X5CrNiMo19-11-2	1.4408	CF8M	17	Hex. nut	Stainless Steel	A 2	1.4301 8
		Stainless Steel	G-X5CrNiMo19-11-2	1.4408	CF8M	18	Spacer sleeve	Stainless Steel	X6CrNiMoTi17-12-2	1.4971 316 Ti
3	Clamping ring	Stainless Steel	G-X5CrNiMo19-11-2	1.4408	CF8M	19	Graphite seal (for metal seat)	Graphite		
		Stainless Steel	X2CrNiMo17-12-2	1.4404	316 L	20	Belleisle spr. washer	Stainless Steel	X10CrNi18-8	1.4310 301 Ti
		Steel	S235JR+N	1.0038+N		21	Bracket	Steel	S235JR+N galvanized	1.0038+N 283-C
4	Shaft	Stainless Steel	X4CrNiMo16-5-1	1.4418		22	Hex. bolt	Steel	St galvanized	CS
		Stainless Steel (< 300°C)	X4CrNiMo16-5-1	1.4418		23	Hex. nut	Steel	St galvanized	CS
		Stainless Steel (> 300°C)	X6NiCrTiMoVB 25-15-2	1.4980		24	Washer	Steel	St galvanized	CS
5	Seat ring	R-PTFE	PTFE-Compound			25	Seal			
		Inconel	Inconel 625			26	Cover plate	Steel	S235JR+N galvanized	1.0038+N 283-C
		FireSafe	PTFE/Inconel 625			27	Hex.-socket screw	Stainless Steel	G-X5CrNiMo19-11-2	1.4408 CF8M
6	Shaft bearing	Stainless Steel	X6CrNiMoTi17-12-2	1.4571 nitrite	316 Ti	28	Centering piece	Stainless Steel	X6CrNiMoTi17-12-2	1.4571 316 Ti
		Stainless Steel	X5CrNi18-10	1.4301	304	29	Countersunk screw	Stainless Steel	A 2	1.4301 SS
7	Gland flange	Stainless Steel	X5CrNi18-10	1.4301	304		Other materials upon request			
		Stainless Steel	G-X5CrNiMo19-11-2	1.4408	CF8M					
8	Thrust collar	Stainless Steel	X5CrNi18-10	1.4301	304					
		Stainless Steel	X6CrNiMoTi17-12-2	1.4571 chr-pld	316 Ti					
9	Bearing ring	Stainless Steel	X6CrNiMoTi17-12-2	1.4571	316 Ti					
		Stainless Steel	X6CrNiMoTi17-12-2	1.4571	316 Ti					
10	Support washer	Stainless Steel	X4CrNiMo16-5-1	1.4418						
		Stainless Steel	G-X5CrNiMo19-11-2	1.4408	CF8M					
11	Taper pin	Stainless Steel	X4CrNiMo16-5-1	1.4418						
		Stainless Steel	G-X5CrNiMo19-11-2	1.4408	CF8M					
12	Plug screw DIN 908	Stainless Steel	G-X5CrNiMo19-11-2	1.4408	CF8M					
		Stainless Steel	G-X5CrNiMo19-11-2	1.4408	CF8M					
13	Seal	PTFE								
		Graphite								
14	Shaft seal	PTFE								
		Graphite								

Subject to change without notice

HIGH PERFORMANCE BUTTERFLY VALVE HP 114

PRESSURE/TEMPERATURE DIAGRAM

- Pressure control line for 1.0619 body material and metal seat
- Pressure control line for 1.4408 body material and metal seat
- - - Pressure control line for R-PTFE

The diagram illustrates the performance of the standard version of our valve type HP. Valves for higher pressure or deviating temperature are available upon request.

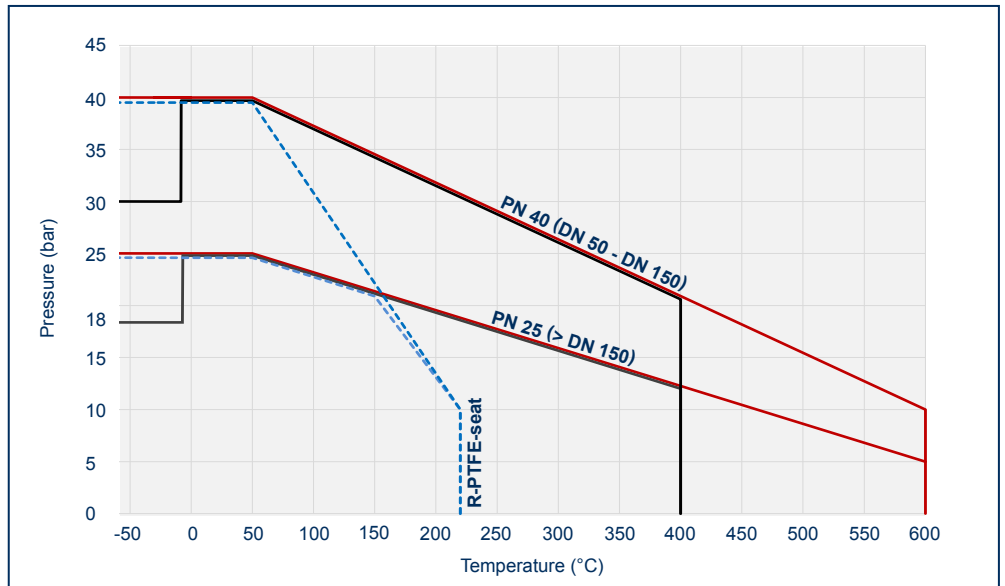

R-PTFE SEAT

The elasticity of the seat ring guarantees sealing according to EN 12266, Leakage Rate A (tight): Leak test with air. The constant test pressure corresponds to the permissible working pressure at 20 °C, not exceeding 6 bar.

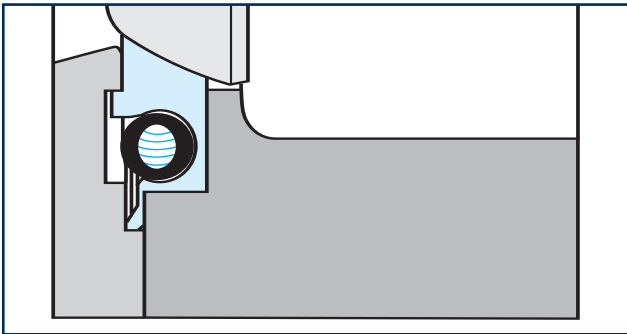

INCONEL

The seat ring made of Inconel and is extremely temperaturestable. Tightness according to EN 12266 Leakage Rate B (tight): Testing conditions corresponding to EN 12266, Leakage Rate B, but test media water.

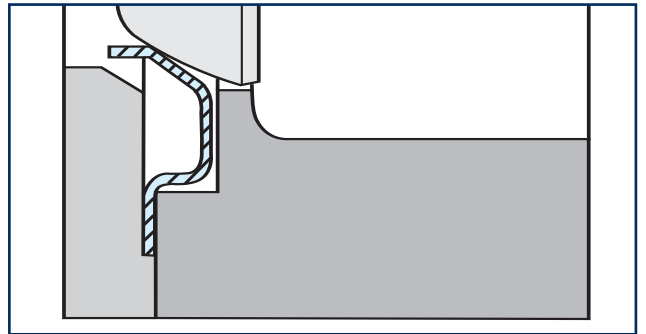

FIRE SAFE SEAT

The combination of a PTFE and an Inconel seat ensures the sealing acc. to EN 12266 (Leakage Rate A) and a metal sealing acc. to API 607 5th edition after heat impact.

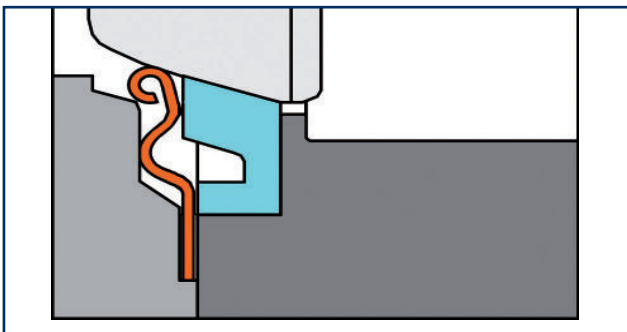

QUALITY FEATURES

HIGH PERFORMANCE VALVE HP 111

STRAIGHT THROUGH SHAFT

ensures maximum bending strength.

MAINTENANCE-FREE BEARING

For all nominal diameters maintenance free, overlong corrosion and temperature resistant bearings are used for exact centring of the valve discs.

FORCE-LOCKED CONNECTION

between disc and shaft. Low shear stresses thanks to tangentially arranged tapered pins.

INCONEL SEAT RING

The Inconel seat ring guarantees absolute tightness and compensates for wear. The seat ring can be replaced without disassembling the shaft and valve disc.

Alternative: R-PTFE or Fire-safe

VALVE DISC

The valve disc has a double eccentric bearing design, resulting in low torques and low wear. All sealing surfaces are machined.

CLAMPING RING

protects the seat ring from abrasion and erosion.

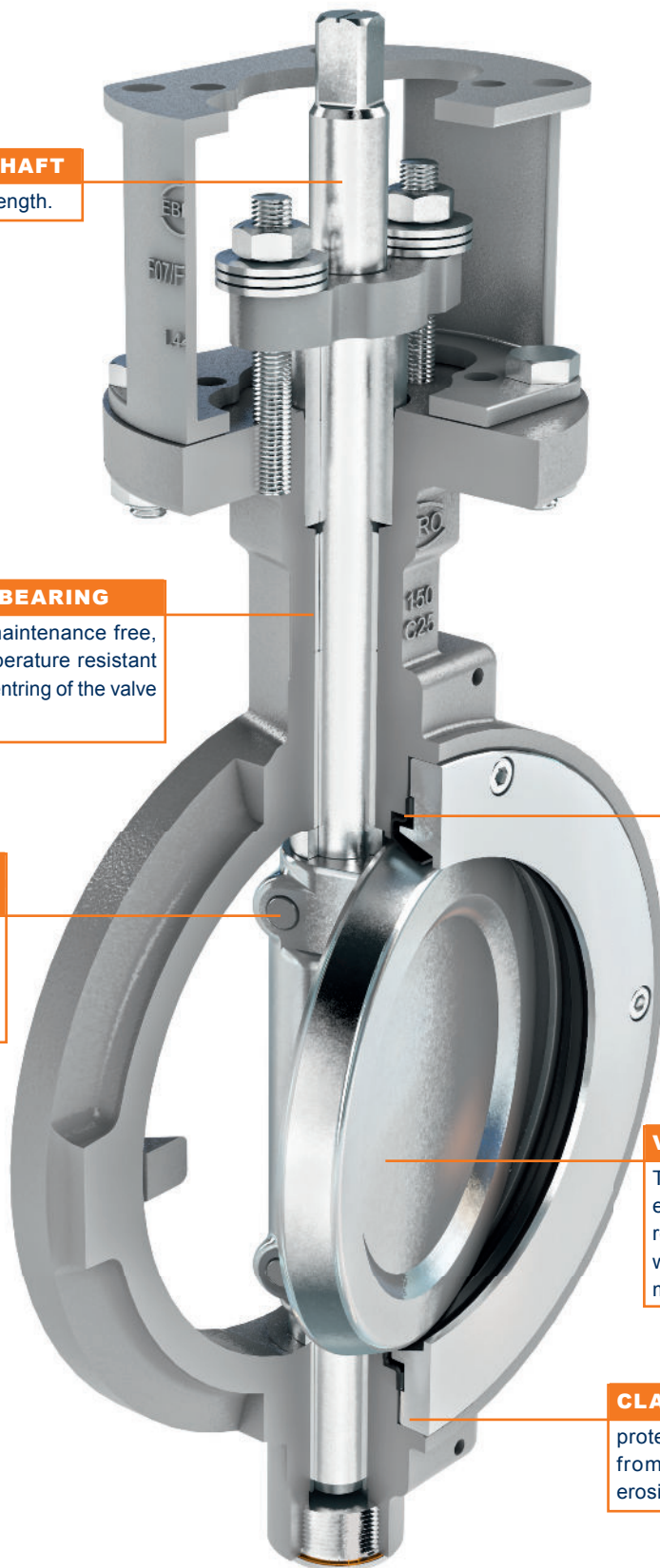

HIGH PERFORMANCE BUTTERFLY VALVE HP 114

TORQUE

- The values specified are based on the initial breakaway torque. (disc disengages from seat, torque then drops)

DN [mm]	Size [in]	Operating pressure							
		10 [bar]		16 [bar]		25 [bar]		40 [bar]	
		R-PTFE	Inconel	R-PTFE	Inconel	R-PTFE	Inconel	R-PTFE	Inconel
50-65	2-2½	27	35	28	42	30	58	31	66
80	3	28	55	30	65	34	90	38	100
100	4	51	90	61	100	80	120	93	140
125	5	63	150	83	172	95	220	125	285
150	6	125	170	136	220	168	300	220	360
200	8	205	350	260	430	280	505	-	-
250	10	485	505	550	620	600	860	-	-
300	12	584	740	700	970	855	1280	-	-
350	14	740	815	930	1050	1200	1370	-	-
400	16	1050	1530	1640	2240	2460	2900	-	-
450	18	1150	1700	1750	2500	2700	3500	-	-
500	20	1210	2010	1800	2760	2800	4260	-	-
550	22	3500	3750	4430	4550	6010	6800	-	-
600	24	4000	4500	4600	5740	6200	8080	-	-
700	28	5300	6000	6100	6800	8100	-	-	-
750	30	5850	7000	6750	8150	8950	-	-	-
800	32	6400	8000	7400	9500	9800	-	-	-
900	36	7800	-	9000	-	12000	-	-	-
1000	40	9800	-	11300	-	15000	-	-	-
1200	48	14300	-	16500	-	22000	-	-	-

All values in Nm

K_V-VALUES

- The K_V-value [m³ per hour] is the flow of water at a temperature of 5°C to 30°C (41°F to 86°F) at Δp of 1 bar

- The K_V-values specified are based on tests carried out by the Delfter Hydraulics Laboratories, the Netherlands

- Permissible velocity of flow
V_{max} 4,5 m/s for liquids,
V_{max} 70 m/s for gases

- The throttle function is linear at an angle 30° to 70°

- Avoid cavitation!

For further values, please contact our engineers.

DN [mm]	Size [in]	Opening angle α°							
		20°	30°	40°	50°	60°	70°	80°	90°
50-65	2-2½	1,3	6	15	18	19	21	22	23
80	3	7	30	50	68	82	97	113	115
100	4	22	60	97	119	164	199	223	251
125	5	45	100	152	195	256	346	452	493
150	6	63	109	162	250	391	588	814	845
200	8	96	168	301	509	742	1107	1581	1747
250	10	264	458	682	980	1421	2083	2882	2889
300	12	397	625	956	1368	1938	2778	3794	3940
350	14	460	720	1100	1650	2500	3400	4800	5400
400	16	550	870	1250	2000	3200	4800	6800	8080
450	18	730	1200	1800	3100	4600	6400	8400	10500
500	20	920	1600	2600	4100	6000	8500	12100	12800
550	22	1090	1950	3100	4600	7500	10200	14700	15300
600	24	1370	2250	3780	4950	9000	12500	17100	18500
700	28	1999	3182	4764	7738	11451	16283	22071	25000
750	30	2400	3850	5700	9300	13700	19500	26500	30000
800	32	2795	4450	6661	10821	16014	22770	30864	34960
900	36	3590	5715	8555	13898	20567	29243	39640	44900
1000	40	4677	7447	11147	18107	26796	38101	51646	58500
1200	48	7188	11444	17130	27826	41179	58552	79367	89900

Subject to change without notice